



TJMC台灣傑特斯

非紅供應鏈產品系列

Non-Red Supply Chain Product Line

TJMC

VIPER 無刷馬達

項目	3115-900KV
尺寸 / 重量	Ø36.4 × 30.1 mm ; 102.6 g
工作電壓	6-8S
最大拉力	≈ 4.23 kgf (4,230 g)
峰值電流 / 最大功率	67.4 A / ≤ 2,000 W
軸徑 / 安裝	5.0 mm 軸 ; M3 × 4 安裝孔

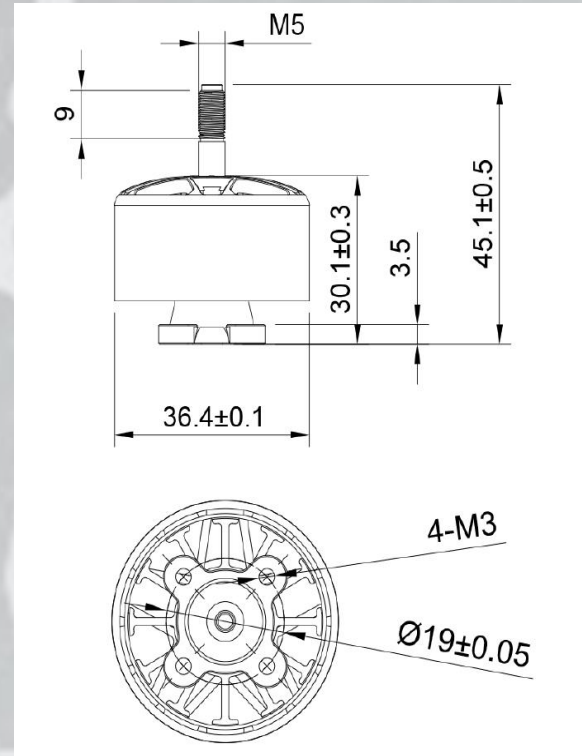

VIPER BRUSHLESS MOTOR

Model	3115-900KV
DIMS / Weight	Ø36.4 × 30.1 mm ; 102.6 g
Operation Power	6–8S
Maximum tension	≈ 4.23 kgf (4,230 g)
Peak current / maximum power	67.4 A / ≤ 2,000 W
Shaft diameter / Installation	5.0 mm shaft; M3 × 4 mounting holes

