



TJMC台灣傑特斯

非紅供應鏈產品系列

Non-Red Supply Chain Product Line

TJMC

VIPER 無刷馬達

項目	2807-1300KV
尺寸 / 重量	Ø32.9 × 20.8 mm ; 53.5 g
工作電壓	4-6S
最大拉力	≈ 2.58 kgf (2,580 g)
峰值電流 / 最大功率	47.1 A / ≤ 1,250 W
軸徑 / 安裝	5.0 mm 軸 ; M3 × 4 安裝孔

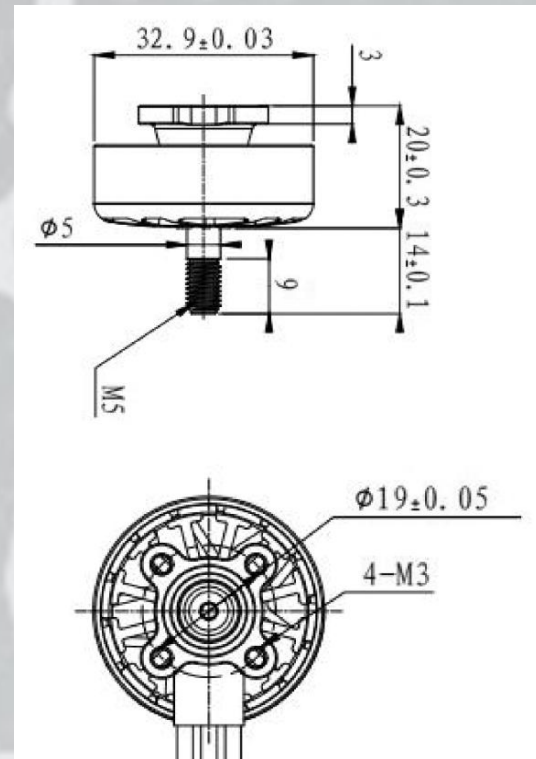

T J M C

VIPER BRUSHLESS MOTOR

Model	2807-1300KV
DIMS / Weight	Ø32.9 × 20.8 mm ; 53.5 g
Operation Power	4-6S
Maximum tension	≈ 2.58 kgf (2,580 g)
Peak current / maximum power	47.1 A / ≤ 1,250 W
Shaft diameter / Installation	5.0 mm shaft; M3 × 4 mounting holes

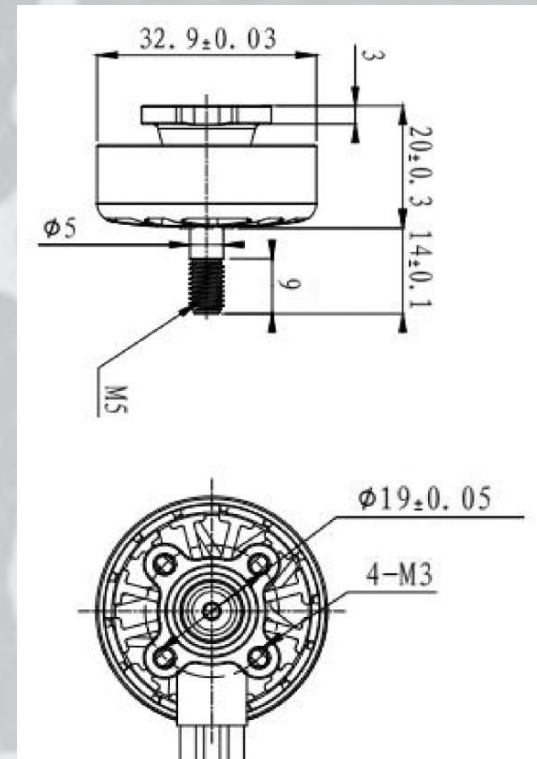

T J M C