



Taiwan Jets Manufacture Co. Ltd.
Non-Red Supply Chain Product Line

TJMC

VIPER BRUSHLESS MOTOR

Model	2807-1300KV
DIMS / Weight	Ø32.9 × 20.8 mm ; 53.5 g
Operation Power	4-6S
Maximum tension	≈ 2.58 kgf (2,580 g)
Peak current / maximum power	47.1 A / ≤ 1,250 W
Shaft diameter / Installation	5.0 mm shaft; M3 × 4 mounting holes

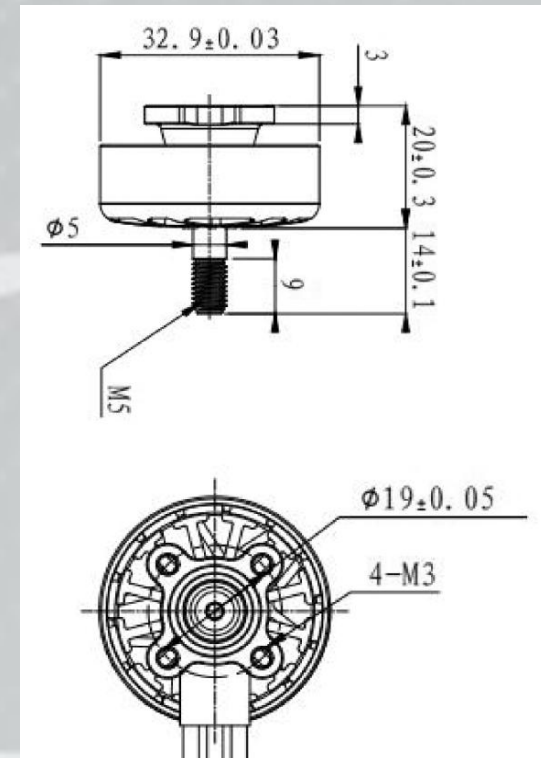

T J M C